

Patient Circuit Arm

For use with SLE4000
and SLE5000 ventilators

The new patient circuit arm is ideal for use with the SLE4000 and SLE5000 ventilators and is designed to fit the rail system on the current range of SLE Medcart trolleys.

The new arm is Swiss-made, and features:

- ✓ Single handed operation
- ✓ Stainless steel construction
- ✓ Fits any standard medical rail
- ✓ Can be used left or right-handed
- ✓ Exact positioning and safe holding
- ✓ Easy to clean
- ✓ Modular design

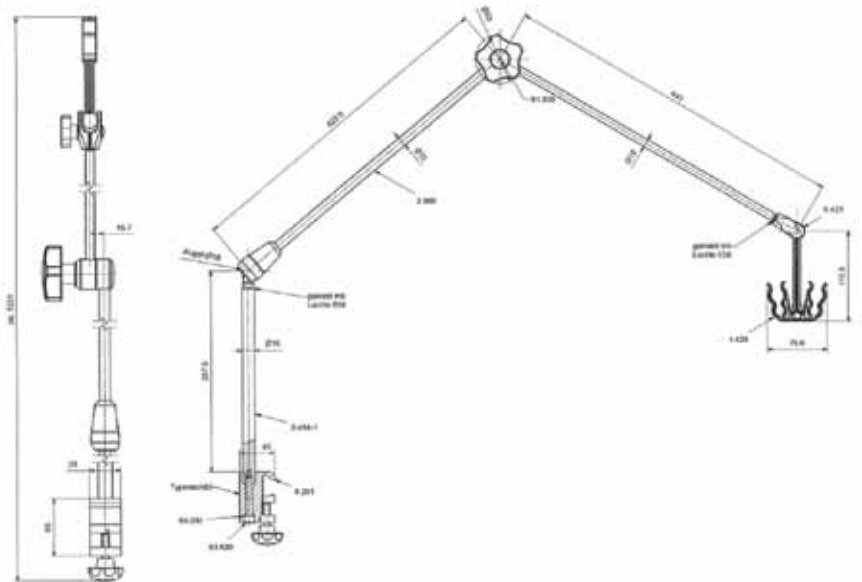

Precise positioning and fixing

The articulated arms can be positioned easily in any desired position. All joints are fixed exactly and held securely in place with the central tightening knob. The short clamping distance and the step-less tensioning system ensure ease of use.

All systems are made of high-quality steel and light alloy and are characterised by a purely mechanical central tightening unit. Their solid quality guarantees a long-lasting service life.

Fisso – a renowned brand

All products are made by specialists using the most advanced technologies available. Their production and further development call for experience and innovative creativity. A high level of personal commitment ensures that all their customers' requirements are met quickly and professionally.

Medicine

The Fisso patient circuit arm has been developed in close cooperation with the University Hospital in Zurich.

They are easy to position and can be fixed in place securely and rapidly with a single knob. The central tightening unit enables simple and fast positioning plus safe holding of breathing circuits, pressure transducers, endoscopes, instruments as well as other medical components and devices.

Thanks to close cooperation with specialists all over the world and their decades of manufacturing experience, Fisso's products are constantly being improved, optimised and perfected.

Part No.	Description
N6627/212	Fisso Patient Circuit Support Arm



SLE Limited, Twin Bridges Business Park, 232 Selsdon Road, South Croydon Surrey CR2 6PL UK
Tel: +44 (0)20 8681 1414 • Fax: +44 (0)20 8649 8570 • sales@sle.co.uk • www.sle.co.uk

Data subject to change without notice